

PRYOR

SERIES 2000

NUMBERERS

Series 2000 Numberers... quick and easy to use... suitable for marking all metals, many plastics etc... for use by either hand/hammer or in most types of marking machines.

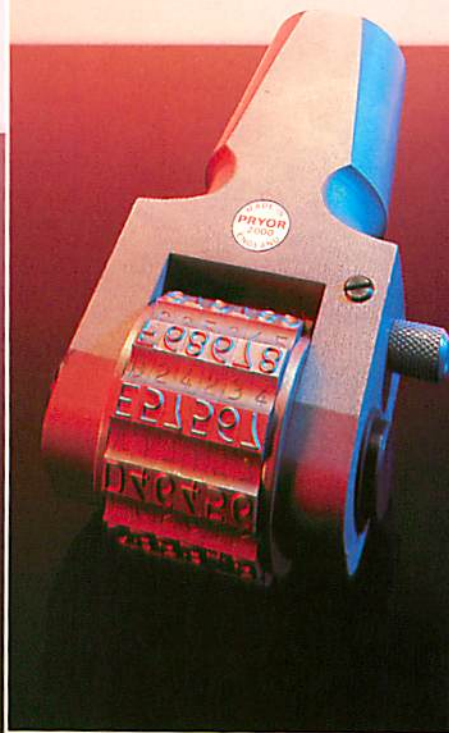
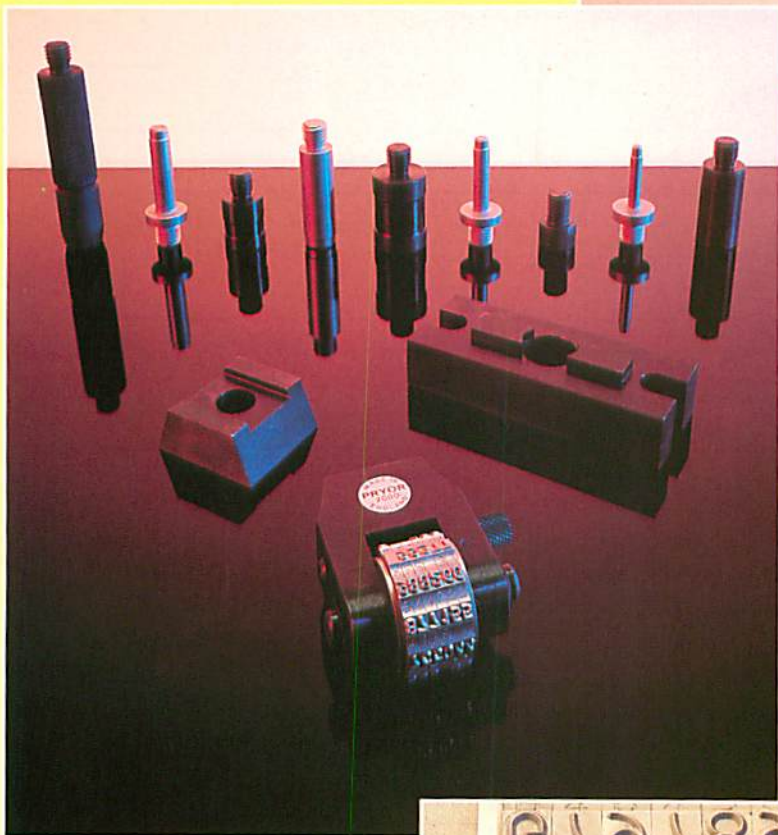

- 7 standard character sizes to choose from.
- Quick and simple inscription change, no tools required.
- Compact and lightweight yet robust and durable.
- Numberers with 1.5, 2.0, 2.5, or 3.0mm characters can be fitted with interchangeable shanks for hand/hammer or machine use.
- Numberers with 4.0, 5.0, or 6.0mm characters have a 'one piece' frame, suitable for heavy duty hand/hammer marking applications.



- Marking Wheels can be rotated to any given position - a complete inscription can be changed in seconds.
- Wheels positively locked in position by a securing pin.

- Tell-Tale characters in the wheel grooves show the actual characters in the marking position - particularly helpful when being used in a machine.
- Positive character alignment gives a quality mark, time after time.

PRYOR
*Marking
technology*

CHARACTERS

Standard wheels have sharp faced characters, 0-9 (inclusive) with one blank station.

Special wheels can be supplied to mark logos, symbols and letters. Character forms can be sharp faced, flat faced, minstress, or dot stress. Styles can be condensed or broad standard style or to any special character style.

Concave and convex characters can also be provided.

SPECIAL FEATURE

The security pin not only fastens the wheels in position, but also transmits the compressive load in the body of the tool, directly to the point of impact.

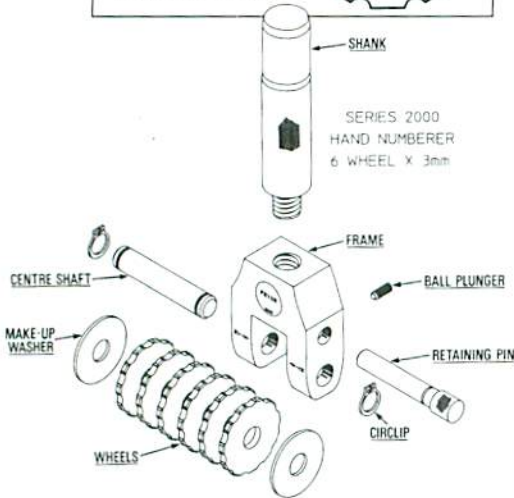
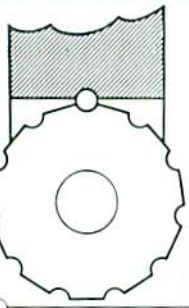

STANDARD SHANKS AVAILABLE FOR USE WITH THE SMALL FRAME NUMBERERS

	Dia. MM	Length MM
Hand shanks	20	88
Machine Shanks	20	25
	20	40
	25.4	38
	6	30
	8	30
	10	40
	16	50

Tenon to suit Pryor Rollmarkers.
Dovetail to suit Pryor mark 32 and 33 Presses.

ACTUAL SIZE, STYLE AND SPACING OF STANDARD CHARACTERS

1.5mm 234567

6.0mm 234567

2.0mm 234567

2.5mm 234567

5.0mm 234567

3.0mm 234567

4.0mm 234567

Standard Letter Style (not at actual size or spacing)

A B C D E F G H I J K L M N O P Q R S T U V W X Y Z

OVERALL LENGTHS OF INSCRIPTION

The chart below shows the actual inscription lengths for the number of wheels and character size required using standard style and spacing.

Using condensed style characters the next size up can be used, without changing the overall length of inscription from that shown for the smaller size, for example 3.0mm condensed characters will give the same overall length as 2.5mm standard.

THE SEVEN STOCK SIZES ARE MARKED IN RED, OTHER SIZES SHOWN CAN BE QUICKLY SUPPLIED

Size	Number of Wheels														
MM	1	2	3	4	5	6	7	8	9	10	11	12	13	14	
1.5	1.5	3.0	4.5	6.0	7.5	9.0	10.5	12.0	13.5	15.0	16.5	18.0	19.5	21.0	Standard Small Frame
2.0	2.0	4.0	6.0	8.0	10.0	12.0	14.0	16.0	18.0	20.0					
2.5	2.5	5.0	7.5	10.0	12.5	15.0	17.5	20.0							
3.0	3.0	6.0	9.0	12.0	15.0	18.0	21.0								Standard Large Frame
4.0	4.0	8.0	12.0	16.0	20.0	24.0	28.0	32.0	36.0	40.0					
5.0	5.0	10.0	15.0	20.0	25.0	30.0	35.0	40.0							
6.0	6.0	12.0	18.0	24.0	30.0	36.0	42.0								

Any special Numberer outside the above range can be considered.

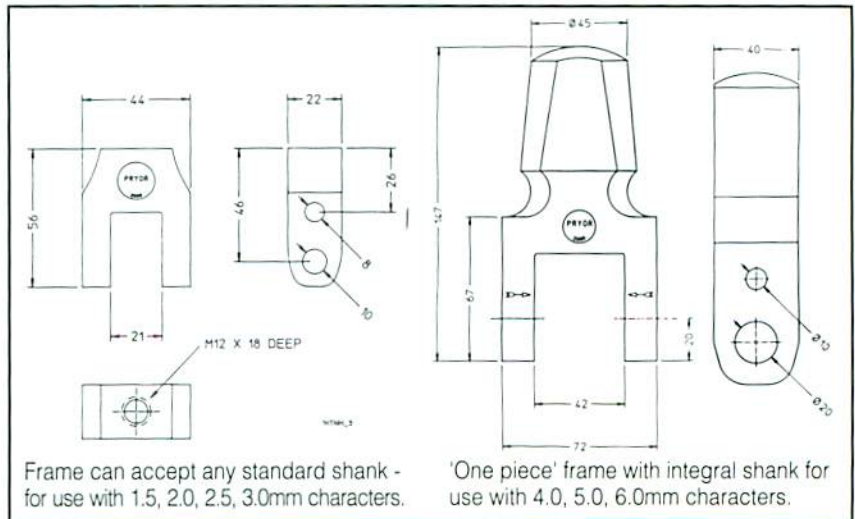

MANUFACTURED BY

EDWARD PRYOR & SON LTD.
EGERTON STREET, SHEFFIELD S1 4JX
FAX: 0114 276 6890 TEL: 0114 276 6044

VILLA LUIGI VILLA & Figlio s.r.l.

NUMERARE - DATARE - CODIFICARE DOCUMENTI E METALLI
MANUALE - AUTOMATICO - ELETTRONICO

Via Statuto, 4 20121 Milano
Tel. 02/6599562 - Fax 02/6590889

www.villamark.it e-mail: info@villamark.it